



AUSTRALIAN
CONSTRUCTORS
ASSOCIATION

Construction & Building Industry Safety Guideline

Single Phase Generators



Disclaimer

This Guideline contains information regarding work health and safety. It includes some of your obligations under the work health and safety and electrical safety legislation that jurisdictional regulators administer. To ensure you comply with your legal obligations you must refer to the appropriate Acts and Regulations that apply in the jurisdiction where you are conducting your work.

This publication may refer to legislation that has been amended or repealed. When reading this Guideline you should always refer to the latest jurisdictional laws. It is the responsibility of the businesses and the individuals involved to ensure that a safe system of work is employed and that statutory requirements are met.

Australian Constructors Association disclaims any and all liability to any person or persons for any procedure, process or any other thing done or not done, as a result of this Guideline.

Construction & Building Industry Safety Standards

Single Phase Generator Guidelines

Intent

To ensure a safe working environment when using a single-phase portable generator and the optimal circumstances for the operation of a 30 Milliamp (mA) Residual Current Device in fault situations.

To ensure correct configuration of portable generator wiring such that permanently connected 30 mA Residual Current Devices operate as designed and provide adequate protection to persons exposed to energised (live) fault conditions.

Scope

This guideline is limited to single phase portable generators and combination engine driven welding sets fitted with a permanently connected 30 mA Residual Current Device (referred to in this Guideline as an RCD) being used for the specific purpose of supplying single phase power to portable electrical equipment via an approved flat pin plug and socket arrangement.

Safety Imperatives

- a. A generating set shall be electrically bonded together to form the generating set bonding system.
- b. A generating set fitted with a permanently connected RCD shall be electrically connected between the generator winding and frame.
- c. A generating set fitted with an RCD shall be tested to ensure the connected electrical device (fixed or plug in i.e. portable RCD) functions correctly to protect persons against electric shock.
- d. A generating set bonding system is generally not required to be connected to the general mass of earth through an earth electrode.

NOTES:

1. *An injection test shall be carried out on any single phase generator fitted with an RCD that is new to the workplace or where the history is unknown to confirm functionality and operation of the RCD as per manufacturer's specifications. Following the initial site test, regular RCD testing must be carried out to comply with local work health and safety regulations and related Australian Standards.*
2. *If the conditions listed in the element guidance below cannot be met, a qualified electrical worker must be consulted to determine a safe electrical configuration prior to using the generating set.*
3. *This is not guidance on electrically connecting a portable generating system to a fixed electrical installation of any type. In this situation refer to Clause 2.4.6.3 of AS/NZS 3012 for guidance.*
4. *Further clarification must be obtained if the working environment is non-land based such as a ship, a barge or similar.*

Australian Constructors Association Construction & Building Industry Safety Guideline

P = Primary responsibility S = Support role / Involved

Electrical Safety Guideline

Imperative Item.	Safety Imperative	Element Guidance	Element Timing	Authorised isolator	Electrical worker	Supervisor	Operator	Safety Practitioner	Workplace Manager	General Manager	Expected Outcome	Standard, Regulation Reference
a.	A generating set shall be electrically bonded together to form the generating set bonding system.	Electrically bonded parts shall include: 1. The engine frame. 2. The generator frame. 3. All exposed conductive parts enclosing electrical equipment or wiring. 4. The 'earth' terminals of any socket outlets. 5. The frame connection.	Prior to Portable Generator use.	NA	P	P	S	P	P	S	All parts comprising the generator bonding system are electrically interconnected in a sound and secure manner with appropriately low impedance between them.	AS/NZS 3010: Clause 2.5.6.2.2
b.	A generating set fitted with an RCD shall be electrically connected between the generator winding and frame.	1. A single electrical connection shall be made from one side of the generator windings to an appropriate part of the generating set bonding system referred to in item a. above. Note: This should be the only connection between the winding and the frame. 2. The input neutral terminal of the RCD shall be connected to the earth terminal of the socket outlet (fixed or portable) and to the generator frame as shown in Figure 1.	Prior to Portable Generator use.	NA	P	P	S	P	S	S	One side of the single phase generator winding is electrically connected or bonded to the frame of the single phase generator. The neutral terminal of the fitted RCD shall be electrically connected to the integral socket outlet earth.	AS/NZS 2790: Clause 6.1
c.	A generating set fitted with an RCD shall be performance tested to ensure the connected electrical device (fixed or plug in i.e. portable RCD) functions correctly to protect persons against electric shock.	To ensure the functionality of a permanently connected RCD : 1. Using an RCD tester, confirm the RCD operates to limit current to 30mA or less within the required tripping time frames for the device type (typically 300 milliseconds (ms) for a Type II RCD). 2. Check that the neutral terminal of the generator upstream of the RCD is connected to the frame terminal. 3. Check that the earth pin(s) of any connected socket outlets, fixed or portable are electrically connected to	Prior to Portable Generator use.	NA	P	P	S	P	S	S	The portable RCD supplied by the portable single phase generator operates to limit current to 30mA or less within the required time frames for a Type II RCD. There is an electrical connection or bond between the generator winding neutral, generator frame and the portable socket outlet earth.	Clause 165 WHS Regulations or jurisdictional equivalent (Qld, Vic & WA) AS/NZS 3012 Clause 3.5 AS/NZS 3760 – Appendix H – Test for the operating time of Residual

P = Primary responsibility S = Support role / Involved

Electrical Safety Guideline

Imperative Item.	Safety Imperative	Element Guidance	Element Timing	Authorised isolator	Electrical worker	Supervisor	Operator	Safety Practitioner	Workplace Manager	General Manager	Expected Outcome	Standard, Regulation Reference
		<p>generating set bonding system.</p> <p>4. Physically check that the neutral wire downstream of the RCD is not electrically connected to any part of the generating set bonding system.</p> <p>See Figure 1.</p>										Current Devices.
d.	A generating set bonding system is generally not required or recommended to be connected to the general mass of earth through an earth electrode.	<p>At 240 V a current of 30mA will not flow if the fault path resistance exceeds 8000 Ohms. Without an earth electrode the current is reduced, but an RCD will operate at 30mA irrespective of the arrangement. The protection is given without an earth electrode. It is considered the possible fault current should be as low as practicable and hence an earth electrode should NOT be used.</p> <p>AS/NZS 3012 provides the following examples of fault current paths and currents that have been considered when deciding an earth electrode is not required:</p> <ol style="list-style-type: none"> The generating set supplies 230V (mains) power via an approved 3 flat pin plug and socket arrangement. The generating set is mounted to or sitting on a truck, utility tray, trailer or the like where the metal frame of the portable generator is in direct contact with the metal frame of the surface it is sitting on. The generating set, when in use, will be sitting on the general mass of earth such as a road, a concrete floor or slab, the ground soil including vegetation. 	Prior to Portable Generator use.	NA	S	P	P	P	S	S	<p>The current required to cause the operation of the RCD in a fault situation is kept as low as possible by ensuring an earth electrode is not fitted unnecessarily.</p> <p>(Lower resistance, as in the case of a fitted earth electrode, equals greater current flow. Conversely, greater resistance, as is the case without a fitted earth electrode equals less current flow.)</p> <p>This in turn increases the amount of electrical protection offered by the RCD.</p>	AS 3012:2010 Clause 2.4.6.3 (c) Note 2

Other Key references applicable to this Safety Guideline are:

AS/NZS 2790-1989 Electricity generating sets — Transportable

AS/NZS 3010-2005 Electrical installations — Generating sets

AS/NZS 3012-2010 Electrical installations — Construction and demolition sites. Note: The standard is adopted as a legal requirement under Clause 163, Work Health and Safety Regulations.

AS/NZS 3000-2007 Wiring Rules

AS/NZS 3760-2010 In-service safety inspection and testing of electrical equipment

Figure 1

Single phase generator winding connections to suit 30mA fixed and portable Residual Current Device operation

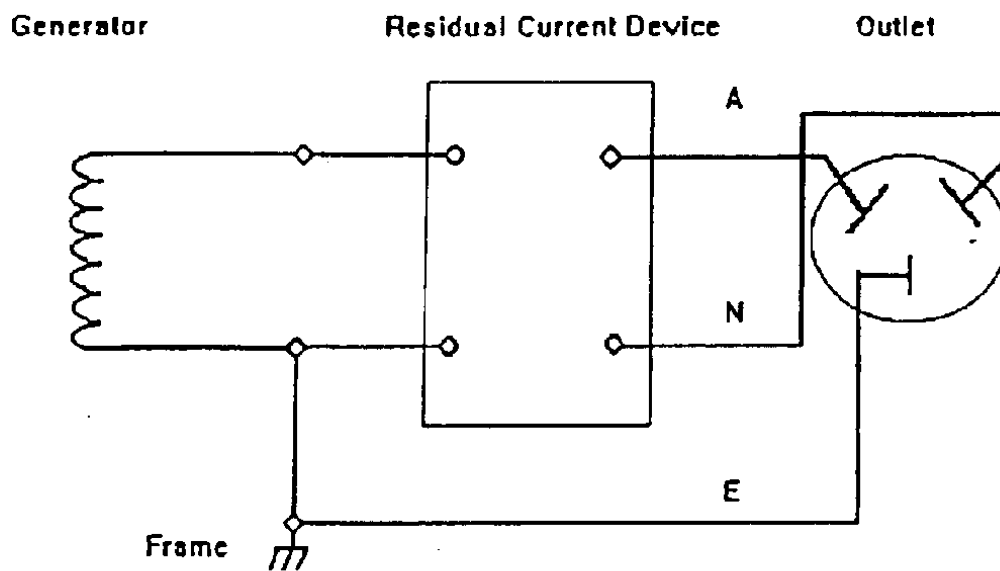

Fig 1